

NUPRESS FACE GLASS AND FIN FITTING: 20-1-CSK

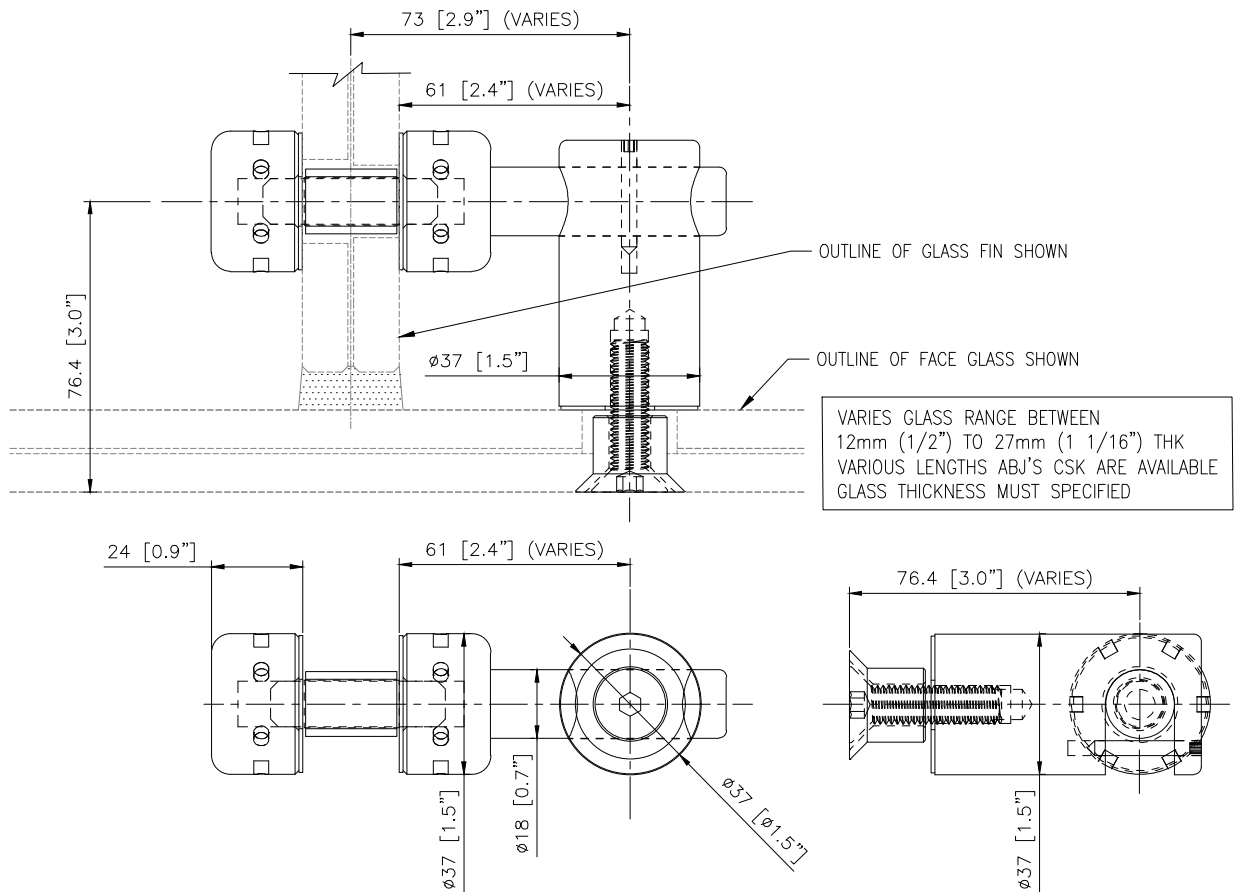

20-1-CSK	
MATERIAL:	316 STAINLESS STEEL
FINISH:	MACHINE FINISH
GLASS CONNECTION STATIC STEM	<p>STATIC COUNTERSUNK GROMMETS ARE AVAILABLE VARIOUS GLASS THK'S FOR GLASS RANGE FROM 12mm (1/2") TO 27mm (1 1/16").</p> <p>STATIC STEMS ARE AVAILABLE VARIOUS SIZES LENGTHS ARE AVAILABLE DEPENDING ON ENGINEERING REQUIREMENTS.</p>
GROMMET GLASS ISOLATOR	COUNTERSUNK ACETAL GROMMET BLACK FINISH
GASKET GLASS ISOLATOR	NEOPRENE 0.8mm (1/32") GASKET. BLACK FINISH

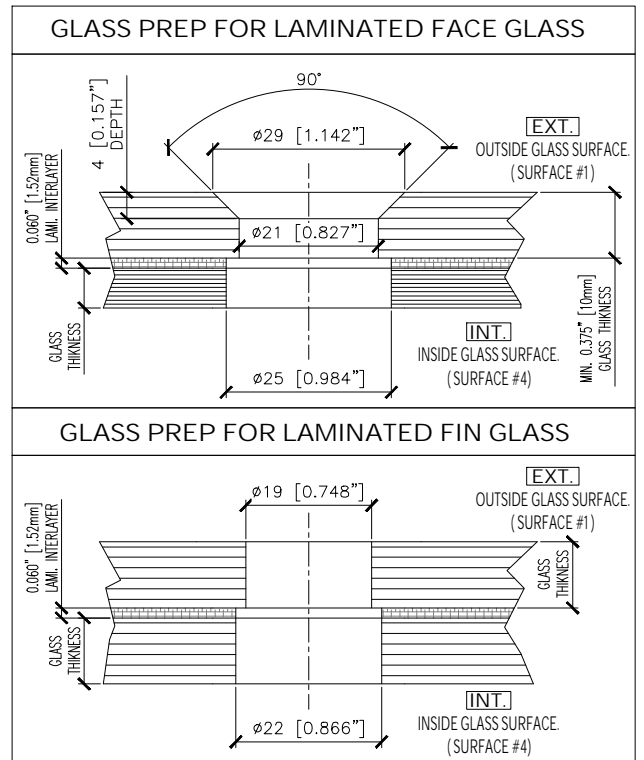

* PRIOR FABRICATING GLASS, CONTACT NUPRESS TO VERIFY GLASS PREP.

THESE DRAWINGS ARE FOR INFORMATION AND CAN NOT BE DEEMED AS ENGINEERED FOR USE IN PROJECT WITH OUT ENGINEERING CERTIFICATION.

NUPRESS GROUP NORTH AMERICA



NUPRESS | FACADES

Part No: **20-1-CSK**